



# CONTROL UNIT SCOR.AS FOR BARRIERS

## Control unit for 1 motor 24Vcc

### 1. Introduction

The control unit SCOR.AS is suitable for the installations of 1 motor with direct current 24V and a maximum absorption of 7A. The control unit allows a precise adjusting of the gates thrust and regulation of the velocity and sensibility on slowing phase. This control unit can memorize up to 30 transmitters and up to 8000 transmitters with the external memory, with the step by step and pedestrian functions. She is provided with inputs for photocell, rib, limit switch in closing and opening and possibility to connect the buttons for step by step, pedestrian and stop. The outputs include a 24 Vac flashing light. Buffer batteries use is available in case it would be necessary to assure the service in case of lack of power.

**WARNING: The adjustments must be carried out so that it is possible to declare the conformity according to the machine directive 98\37\CE (Machine Directive) and particularly to the EN 12445; EN 12453 ed EN 12635 regulation and successive modifications.**

### 2. Configuration

#### Trimmer of regulation:

TR1: RUNNING AMP.SENS.  
TR2: SLOW.DOWN AMP.SENS  
TR3: SLOW.DOWN VELOCITY  
TR4: AUTOMATIC RECLOSING

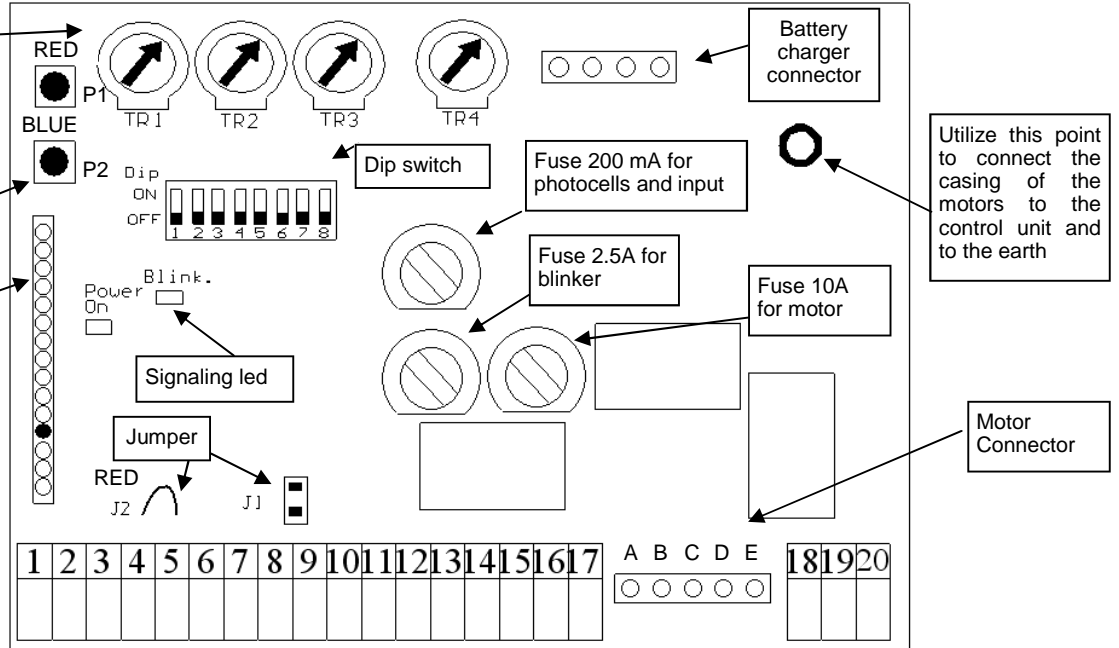

### 3. Electrical connections

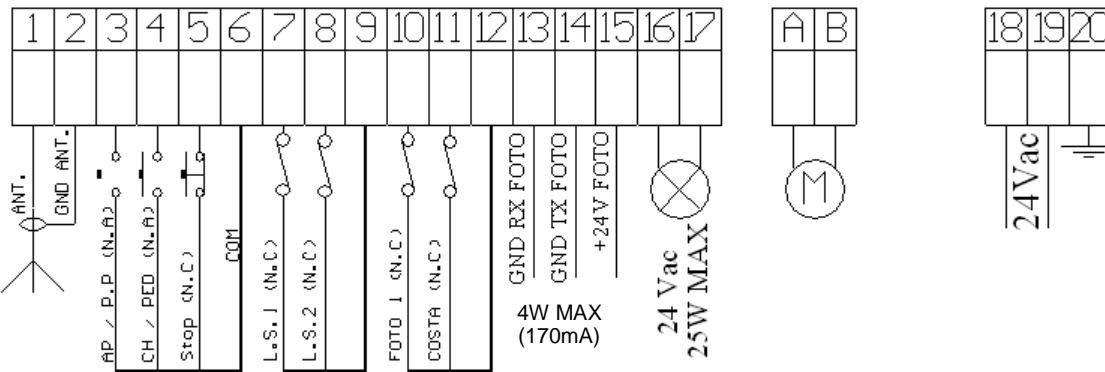

Examples of maximum load for Vdc accessories (4W):

- 3 couples of FTALL photocells.
- 2 couples of FTALL photocells and 1 R.CO.O receiver (safety edge system).
- 2 couples of FTALL photocells and 1 B.RO X40 DISPLAY receiver.
- 1 couples of FTALL photocells and 1 B.RO X40 DISPLAY receiver and 1 R.CO.O receiver.

#### Table of contents:

S.STEP: Step by step button / Open.  
PED: Pedestrian button / Close.  
Stop: Stop.  
Com: Common.  
GND ANT.: Braiding antenna  
ANT.: Antenna  
Photo: Photocell.  
Costa/orol.:input rib/clock.  
L.S. OP.: limit switch opening / closing  
L.S.CL.: limit switch closing / opening

**Any Normally Closed contact (N.C.) must be jumped to the common if not utilized.**

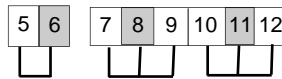

#### Motor Connector

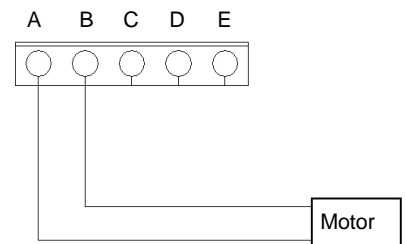

### EARTH CONNECTION

In order to obtain correct operation of the accessories (photo devices in particular) connected to the control panel, it is very important that the entire system (automation + motors + control panel) has a single mass reference. You must therefore connect the metallic automation structure, the motor casing and the control panel to each other with the terminal earthed. For the connection on the control panel see figure 1

**WARNING: Before carrying out any activation and/or setting up, carefully read the following paragraphs which describe the programming and the main setting up of the automation. During the programming, carefully follow the order and the instructions shown. Do not enter into the working range of the system whilst it is moving or being programmed. Before carrying out any modification wait for the complete stop of the system. Do not allow unauthorized and/or unqualified people to intervene or to enter into the system's working range.**

#### 4. Preliminary checks

Before giving power to the control unit, check all the connections carried out. Check particularly that there are no grazed cables, short circuits between the wires and that all the accessories are connected to the terminal on the points indicated on the scheme at page 1. Once given power supply check that:

1. The led POWER is light on fix
2. The inputs normally closed must have the correspondent led lighted on. The led must turn off itself when the contact of the input opens itself.
3. Check that the radio module is connected and functioning
4. Put the DIP 1 on ON

Check the connection of the motors following this procedure:



**Note: during these handlings the photocells, the radio and the buttons ARE NOT active.**

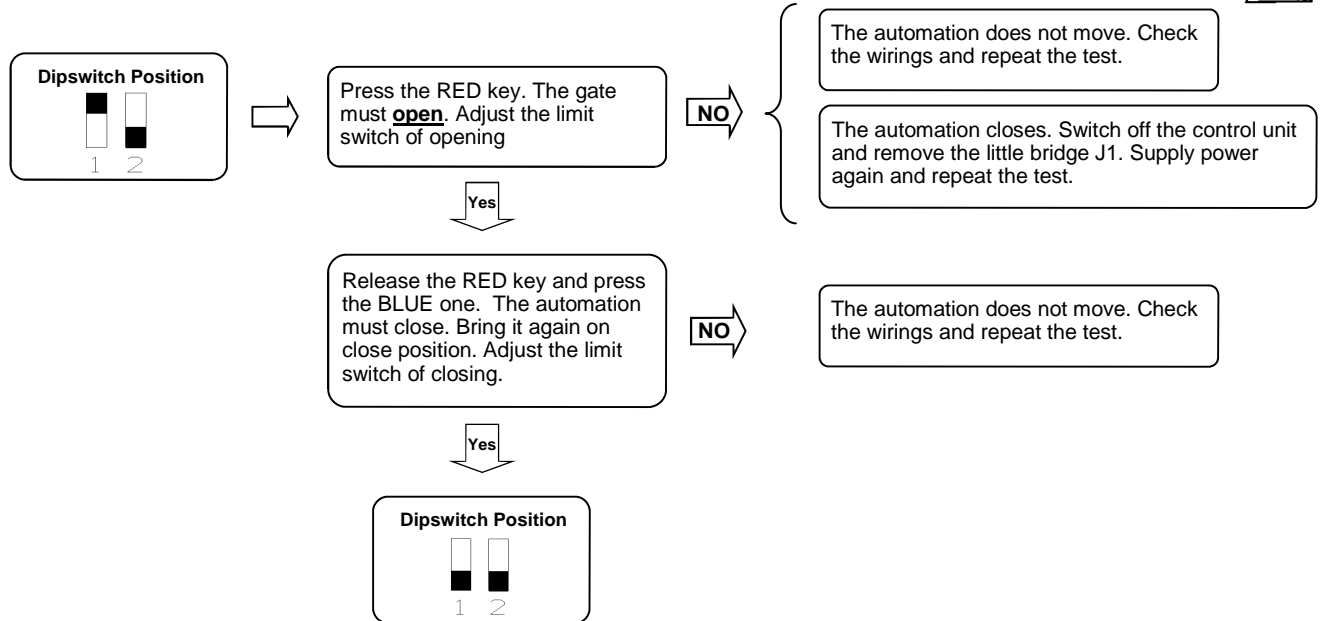

**Warning: the removing of JUMPER 1 must be carried out with control unit switched off. As soon as the control unit switches on again, the motor rotation sense and the limit switches inputs are automatically inverted. It is advisable to check the correct functioning of the limit switches with the operations above described.**

**WARNING: THE LIMIT SWITCHES MUST BE ADJUSTED IN WAY THAT THE AUTOMATION DOES NOT PRES EXCESSIVELY. A WRONG REGULATION OF THE LIMIT SWITCHES CAN REDUCE THE AVERAGE LIFE TIME OF THE AUTOMATION.**

#### 5. Remote control learning

Memorize at least one 2-key remote control. In order to program the wing stroke use a 2-key remote control. During normal operation however, (i.e. not during programming) the 1st memorized key carries out the step by step function (opening and closing of the gate), the 2° key handles the pedestrian function (partial opening). The 3° key handles courtesy light.

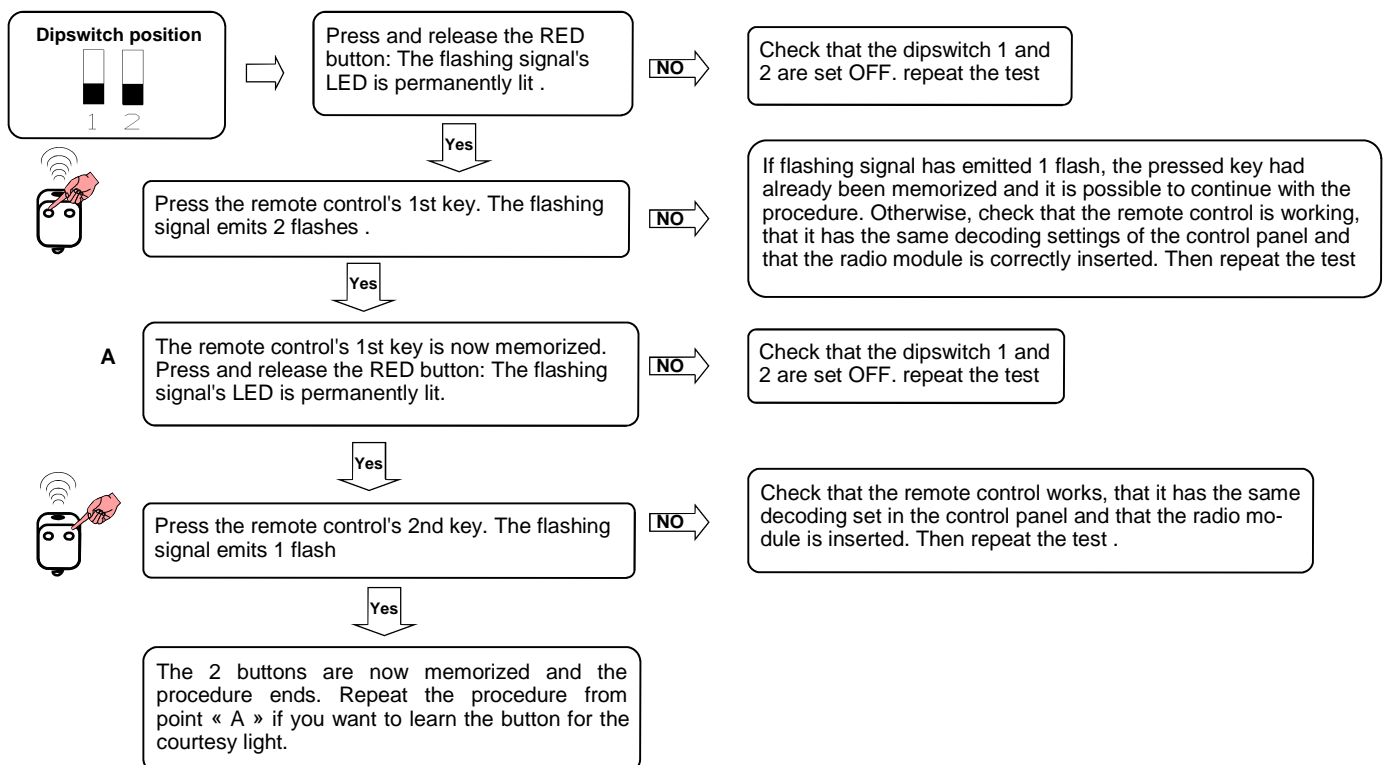

## 6. Setting the wing stroke

This procedure must ONLY be carried out by the installer and ONLY during the put in function of the system. If a transmitter is not utilized, it is necessary to use the red key (P1) present on the card or with the P.P. buttons. Then you must carry out the following procedure:

1. Close the gate, see point 4 to move manually the automation
2. Put the DIP1 on OFF
3. Put the DIP 2 on ON. The flashing light blinks slowly
4. The system automatically stops on the mechanical stop or on the limit switch.

### Setting of the course of the wings

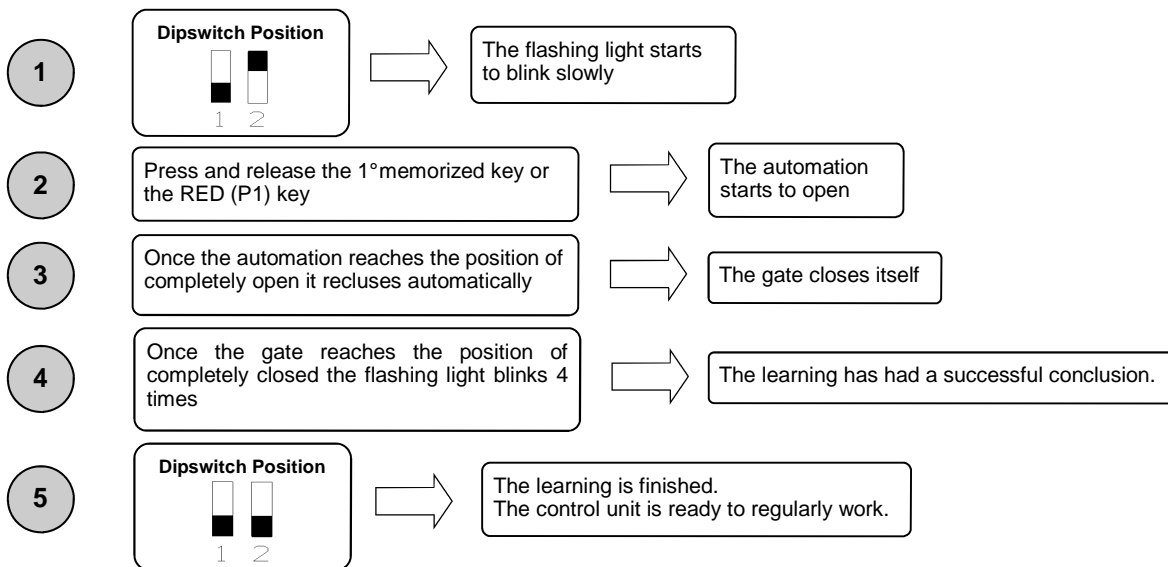

## 7. Adjusting threshold of the ampere sensor operating

This procedure must ONLY be carried out by the installer and ONLY during the put in function of the system. For a correct programming, before carrying out the modifications, bring always back the door to the totally closed position.

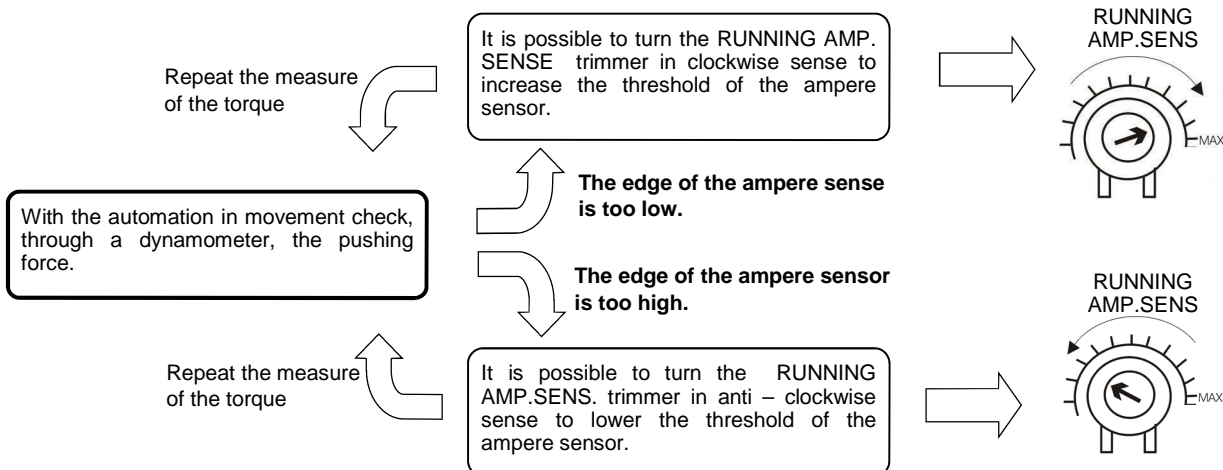

**WARNING:** The adjustments must be carried out so that it is possible to declare the conformity according to the machine directive 98\37 \CE (Machine Directive) and particularly to the EN 12445; EN 12453 ed EN 12635 regulation and successive modifications.

## 8. Adjusting threshold of the ampere sensor in slowing down

This procedure must ONLY be carried out by the installer and ONLY during the put in function of the system. For a correct programming, before carrying out any modification, bring always back the door to the totally closed position.

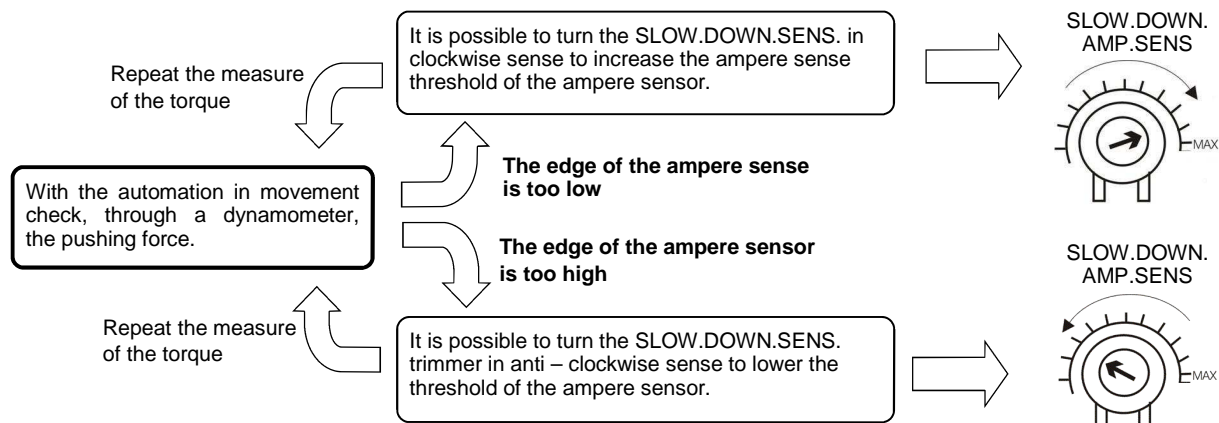

**WARNING:** The adjustments must be carried out so that it is possible to declare the conformity according to the machine directive 98\37 \CE (Machine Directive) and particularly to the EN 12445; EN 12453 ed EN 12635 regulation and successive modifications.

## 9. Adjusting of the motors velocity in slowing down

This procedure must ONLY be carried out by the installer and ONLY during the put in function of the system. For a correct programming, before carrying out any modification, bring always back the door to the totally closed position.

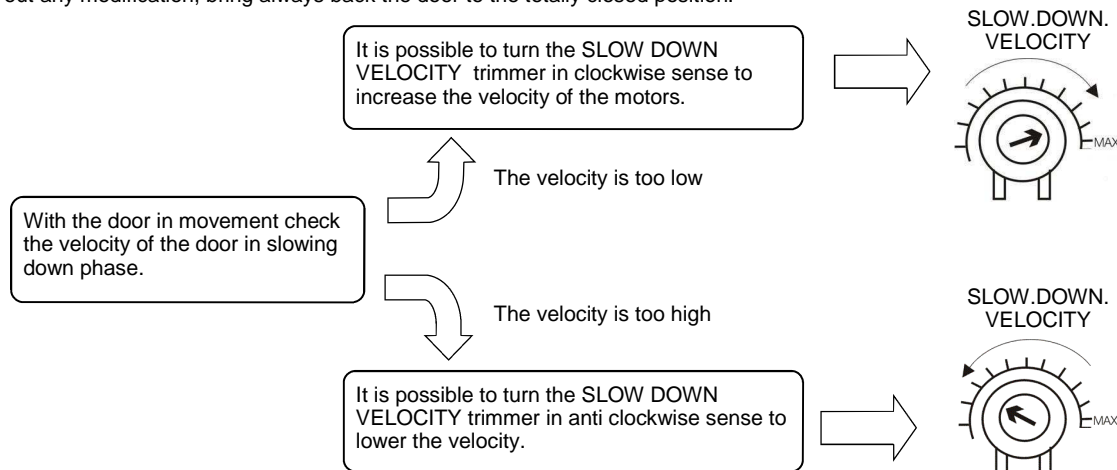

**WARNING:** it is indispensable to carry out, after adjusting the desired velocity in slowing down, a new programming of the strokes in the case in which the slowing down phase is personalized.

**WARNING:** The adjustments must be carried out so that it is possible to declare the conformity according to the machine directive 98\37 ICE (Machine Directive) and particularly to the EN 12445; EN 12453 ed EN 12635 regulation and successive modifications.

## 10. Adjusting of the automatic reclosure time

This procedure must ONLY be carried out by the installer and ONLY during the setting up of the system. For a correct programming, before any modification, bring always the gate back to the totally closed position.

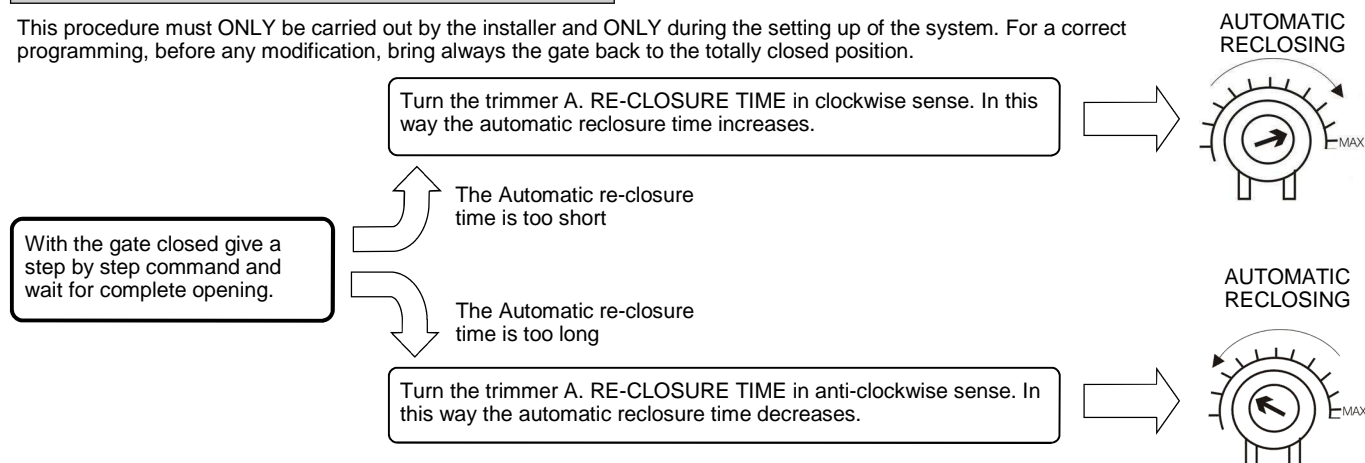

### Disabling of the automatic re - closing

Turn the trimmer A. RE-CLOSURE TIME completely in clockwise sense. In this way the automatic reclosure is disabled.

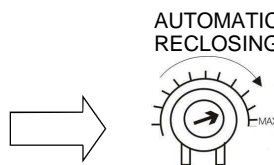

### Automatic reclosing by photocells

Turn the trimmer AUTOMATIC RECLOSING completely in anti-clockwise sense to enable the photocells automatic reclosing. If the photocells beam is not interrupted, the control unit re-closes itself after 2 min.

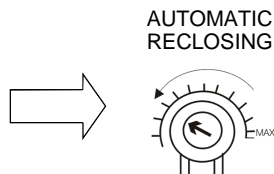

## 11. Personalization of pedestrian opening (partial opening)

This procedure must ONLY be carried out by the installer and ONLY during the put in function of the system. For a correct programming, before carrying out any modification, bring always back the door to the totally closed position. If it is not personalized, the pedestrian opening corresponds to the total opening of the automation.

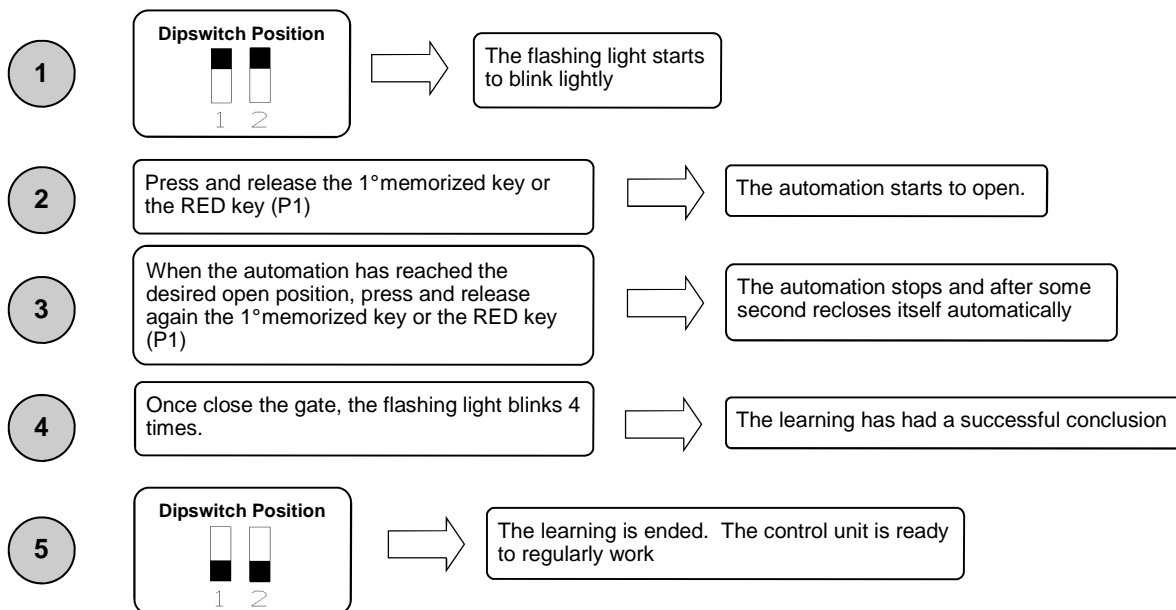

## 12. Personalization of the slowing down phase

This procedure must ONLY be carried out by the installer and ONLY during the put in function of the system. For a correct programming, before carrying out any modification, bring always back the door to the totally close position. If the pedestrian opening is not personalized, it corresponds to the total opening of the automation. During the learning phase it is possible to decide where the automation must start the slowing down phase.

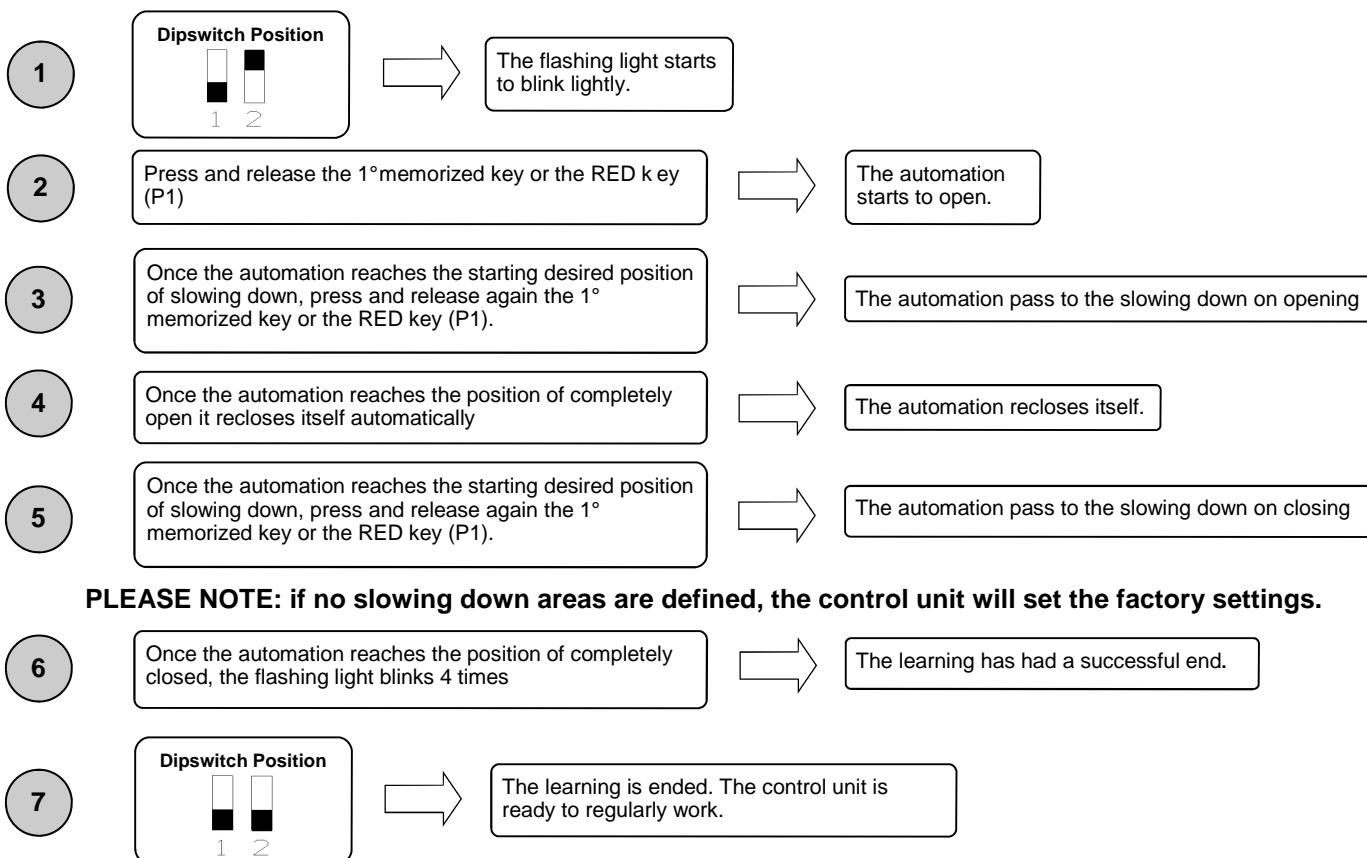

**PLEASE NOTE: if no slowing down areas are defined, the control unit will set the factory settings.**

**PLEASE NOTE: it is indispensable, after setting the desired velocity on slowing down, to carry out a new programming of the stroke in case in which the slowing down phase is personalized.**

## 13. Advanced functions

Through the 8-position dip switch, it is possible to personalize further the automation functions. As standard the control panel leaves the factory with all the main functions already set, however, it is always possible to modify them by following the table:

Dip No.	function	Dip OFF	Dip ON
1	modality of functioning	Automatic	Manual
2	Strokes learning	disabled	enabled
3	Pre-flashing	Not active	Active
4	Condominium function	Not active	Active
5	input functioning	Step by step/pedestrian	Open/close
6	Photocell check	disabled	enabled
7	time set	Not active	Active
8	velocity of the automation	Reduced	Maximum

### 13.1 Modality of functioning

Setting the dip n°1 on ON and the dip n°2 on OFF, the manual functioning is enabled. This functioning allows the displacement of the wing with the red and blue keys present on the card (see section 4)

### 13.2 Strokes learning

Setting the dip n°1 on OFF and the dip n°2 on ON, the learning of the strokes is enabled. This functioning allows to learn the courses and the phase shift of the wings (see section 6).

Setting the dip n°1 on ON and the dip n°2 on ON, the pedestrian opening is enabled. This functioning allows to learn the opening of the first wing when the pedestrian opening key is pressed (see section 11).

### 13.3 Pre – flashing

Setting the dip nr.3 on ON the pre – flashing is enabled. This function means that before any movement there will be a brief flashing in order to indicate the movement is about to begin. Remember to turn the control unit off and then on again after modifying the dip switch's configuration.

### 13.4 Condominium function

Every command sent via radio or with the step by step buttons and/or pedestrian buttons will only open the automation. Reclosure is entrusted to the automatic reclosure function, which **must be activated** since all closure command are ignored. In case the condominium function is active and the automatic reclosure is deactivated by means of the respective regulation trimmer (turned completely in clockwise sense), the control panel puts itself in state of signalled alarm, with door closed, through fast blinkings of the flashing light. Set dip n°4 on ON to activate the condominium function.

### 13.5 Functioning of wired inputs

Setting the dip n°5 on OFF the **wired** inputs step by step and pedestrian are enabled.

Setting the dip n°5 on ON the **wired** inputs Open and Close are enabled.

### 13.6 Photocells check

This control unit is equipped with a function which allows you to carry out a check of the photocells operation before any turning on of the motor. In this way there is the possibility of increasing the safety of the system in case of photo device damaging (for example output relay stuck) or of an unwanted short – circuit on the photocell input. In case of breakdown, the control panel will signal it through a single flashing when a key is pressed and no movement will take place. This check is carried out after the control panel has received an order to move, but therefore powering the motor. Set dip n°6 on ON to activate the photo cell check.

### 13.7 Clock function

Setting the dip n°7 on ON the timing function is activated. The **rib** input becomes **timing** input where it is possible to connect a timer for the programming opening of the gate. The contact is interpreted as request of opening and of permanence on the opening state until the contact remains closed. When the contact opens, the gate automatically closes.

### 13.8 Velocity of the automation

The control unit SCOR.AS can work at 2 speeds. This setting is carried out positioning the dip nr.8 on OFF if you want the functioning at reduced speed and on ON if you want the functioning at maximum speed. This setting **MUST** be carried out **BEFORE** of the learning of the strokes.

**WARNING: The adjustments must be carried out so that it is possible to declare the conformity according to the machine directive 98\37 CE (Machine Directive) and particularly to the EN 12445; EN 12453 ed EN 12635 regulation and successive modifications.**

## 14. Modality of photocells intervention

The modality of photocells intervention is only one:

- The photocells do not intervene on opening, while they immediately invert the movement until the complete re opening in case of obstacle in closing.

## 15. Modality of ribs intervention

The modality of rib intervention is only one:

- The rib does not intervene on opening, while it immediately inverts the movement until the complete re – opening in case of obstacle on closing.

**WARNING: WITH THE DIP 7 ON ON THE RIB INPUT BECOMES CLOCK INPUT. TO UTILIZE THE RIB, PUT THE CONTACT OF THE RIB IN SERIES WITH THE CONTACT OF THE PHOTOCELLS OR WITH THE STOP.**

## 16. Control unit operation mode

The modality of intervention of the current sensor is only one. In case of intervention of the sensor in opening, the gate stops. In case of intervention in closing, the immediate inversion is got with the total re opening of the gate. In case the condominium function is selected, the happening of a sense in closing involves a short inversion in opening with a successive stop of the motion until the reception of an order.

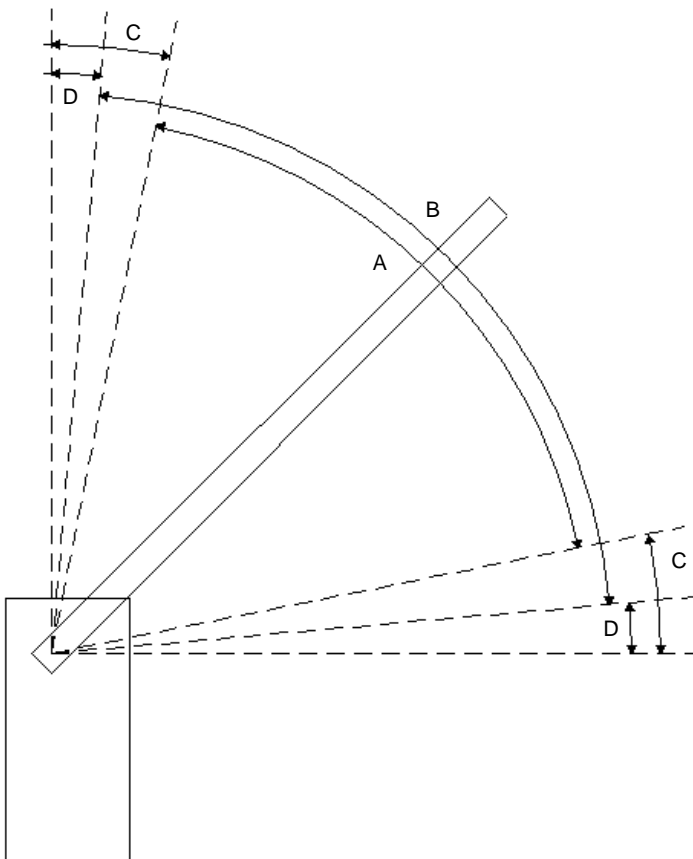

A= Intervention zone of the amperometric sensor with movement inversion

B= Normal speed run zone

C= Intervention zone of the amperometric sensor with movement stop and setting of the reached position as total closing/opening position.

D= Low speed run zone

**WARNING:** cutting the little bridge "J2" (red) the re - synchro zone is deleted (zone D). This means that the control unit won't stop for sense of current but will go on until the reach of the limit switches that therefore **must obligatory be installed and functioning.**

## 17. Selection of the decoding type and total deletion of the memory

In case it would be necessary to modify the decoding type (from rolling code to fix code or vice versa), or cancel all the learned transmitters, proceed as follows:

1. Cut off the power supply to the system
2. Press the **blue** key if you want to select the fix code decoding or press the **red** if you want to select the rolling code decoding
3. Keep them pressed while you give again tension
4. Keep them again pressed until the flashing light lights on 3 times
5. At this point release the key and wait until the flashing light lights off. The selection of the decoding and the total deletion of the memory have been carried out.

## 19. State of alarm of the control unit

If the flashing light blinks fastly or remains light on fix, it means that the control unit is in state of alarm. Any command is ignored until the resolution of the problem.

Type of problem	Probable cause	Solution
Fast blinking of the flashing light	Condominium active + automatic reclosure deactivated	Enable the automatic re-closure by turning the trimmer in anti clockwise sense or deactivate the condominium function (dip 4 off).
Flashing light still and lit	Intervention of thermal protection of the control unit. Too high stream absorption. The value must not be higher than 7A for more than 3 sec.	Each command is ignored for 20 seconds. Check the motor status and their absorption.

## 20. Problem solving

This paragraph intends to give some indications for solving the most common problems. Before proceeding, check that the LED present on the panel are correctly on or off, according to the following diagram:

LED STATUS						
Step by step/open	Pedonale / Chiudi	stop	Photocell	Rib/clock	Limit switch opening	Limit switch/closing
spento	spento	acceso	acceso	Acceso / spento	acceso	acceso

If one or more LED are not in the correct status check the corresponding input. In case exclude the external accessories bridging the related inputs (photocell, stop, limit switch) with the common in case of normally closed contact. Check the points in the following table:

Type of problem	possible cause	Solution
On activating the open command, the wings do not move.	Loss of electrical power.	Check the presence of electrical power and all the connections of the electrical network.
	Burned fuse	Replace the fuse with one with the same characteristics
On activating the open command, the wings close.	Motor cables inverted	Check motor wiring, inverting them if necessary or remove jumper J1 .
Impossible to programme remote controls.	<ul style="list-style-type: none"> <li>The dipswitch are not correctly putted</li> <li>The type of decoding set in the control panel does not correspond to the type of remote control used.</li> </ul>	<ul style="list-style-type: none"> <li>Put dip 1 and 2 on OFF</li> <li>Check which decoding was set and select the one which corresponds to the remote controls in use.</li> </ul>
It is impossible to enter in wing stroke programming mode.	The gate is not closed	Close (in manual) the gate. Try again to enter into setting mode.
The control unit is power supplied but the automation doesn't move	A normally closed input is not active	Check the photocells input, stop and the limit switches. If not used, jumper it to the common
During the learning, a wing stop before to reach the total opening.	RUNNING AMP.SENS. Trimmer threshold too low	Increase the intervention value of the ampere sensor.
On learning phase, le wings arrive on total opening but the gate does not re-close.	RUNNING AMP.SENS. Trimmer threshold too high	Decrease the intervention value of the ampere sensor.

**GUARANTEE** - In compliance with legislation, the manufacturer's guarantee is valid from the date stamped on the product and is restricted to the repair or free replacement of the parts accepted by the manufacturer as being defective due to poor quality materials or manufacturing defects. The guarantee does not cover damage or defects caused by external agents, faulty maintenance, overloading, natural wear and tear, choice of incorrect product, assembly errors, or any other cause not imputable to the manufacturer. Products that have been misused will not be guaranteed or repaired. Printed specifications are only indicative. The manufacturer does not accept any responsibility for range reductions or malfunctions caused by environmental interference. The manufacturer's responsibility for damage caused to persons resulting from accidents of any nature caused by our defective products, are only those responsibilities that come under Italian law.